

<b>SPECIFICATION</b>	
<i>MODEL NAME: LEB1275-120-3.1-7.6-R-LAB</i>	

### LEB1275-120-3.1-7.6-R-LAB ELECTRO-MAGNETIC BUZZER

1	Rated Voltage (VDC)	12
2	Operating Voltage (VDC)	9~15
3	*Resonant Frequency (KHz)	3.1±0.3
4	*Sound Output at 10cm (dB)	≥85
5	*Current Consumption (mA)	≤30
6	Operating Temperature (°C)	-40~+85
7	Storage Temperature (°C)	-40~+90
8	Weight (g)	0.8
9	Housing Material	PPO

\*Applying rated voltage (VDC)

### DIENSIONS (UNIT: mm)

Tolerance: ±0.5mm Except Specified

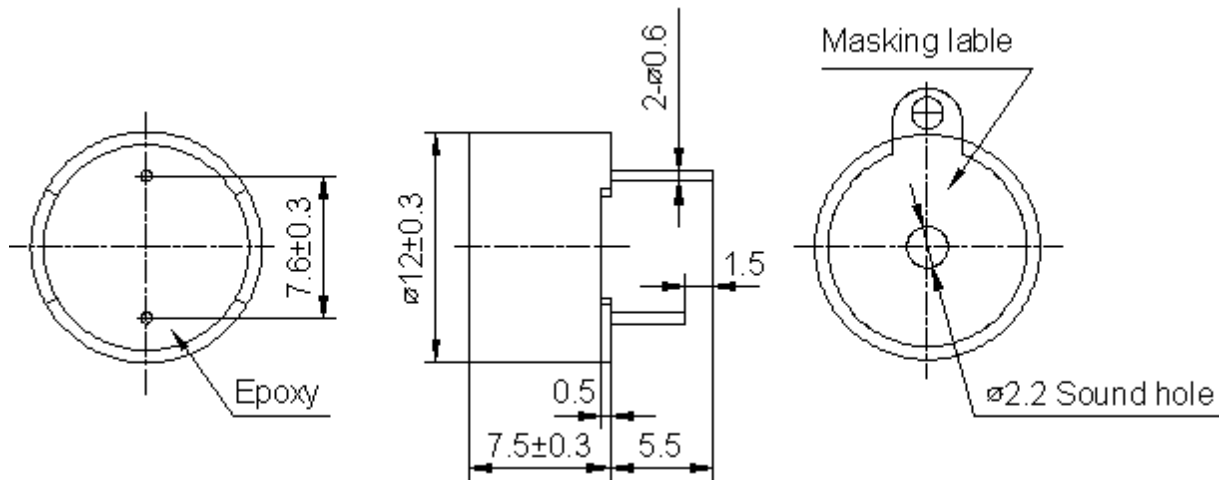

**TEST METHOD:**

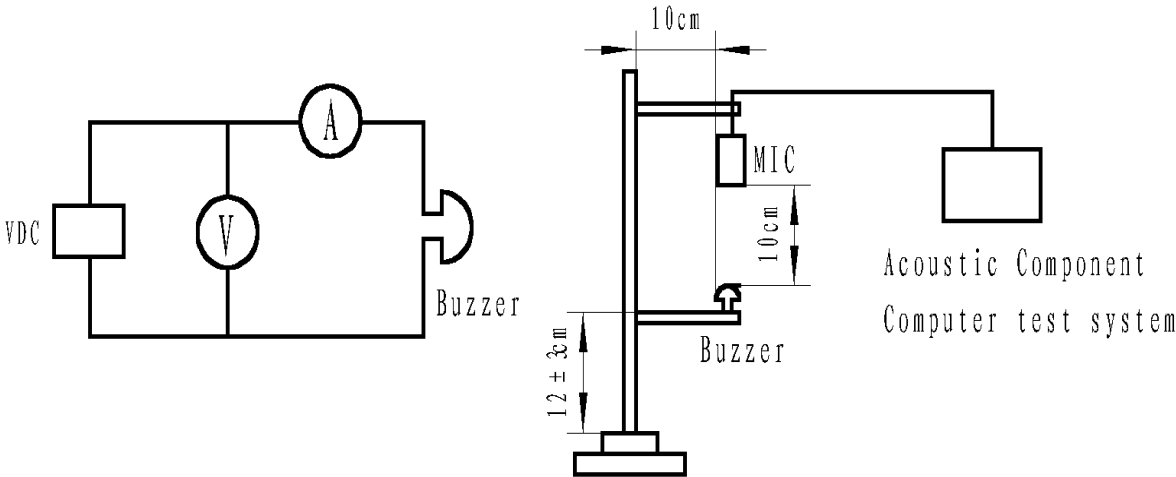

**Input Voltage VS. Sound Pressure Level & Current Consumption**

