

REV.	DESCRIPTION	DRAWN	CHECKED	APPROVED
A	NEW RELEASE	LJH 08/13/05'		

BOM LIST			
ITEM	PART NAME	Q'ty	NOTES
1	PLASTIC HOOD	2	ABS
2	BOLT	2	#4-40
3	NUT	2	M3
4	LONG SCREW	2	M3
5	SMALL WASHER	2	
6	SHORT SCREW	2	M3
7	MIDDLE WASHER	2	M3

NOTES:  
1. PART NUMBER CODE:  
DS1046 - 09 X X X

Bolt type  
L: Long  
S: Short

Packing type  
1: Mix packing  
2: Separation packing

Cover Material  
C: Chromium Plated

Positions  
09: 9pin

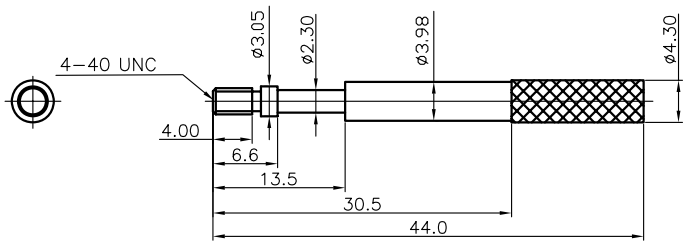
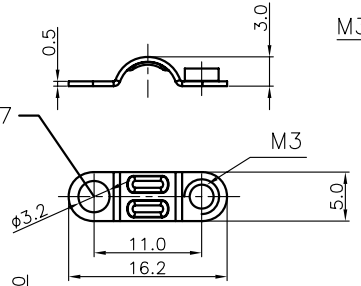
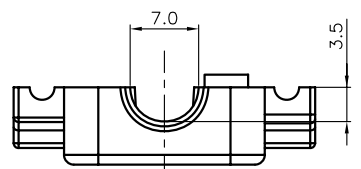
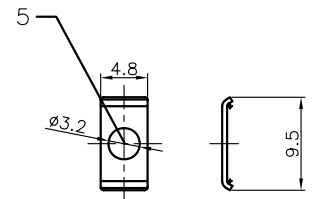
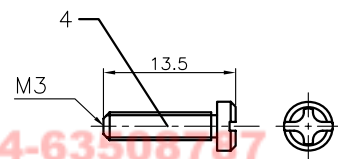
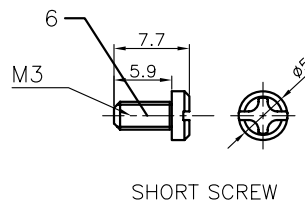
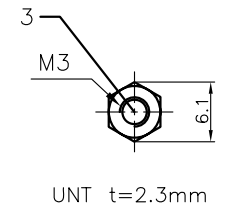
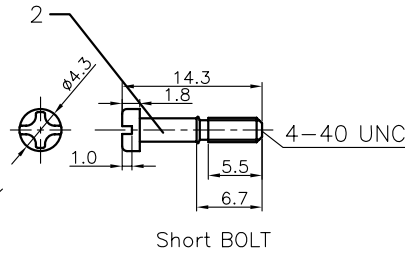
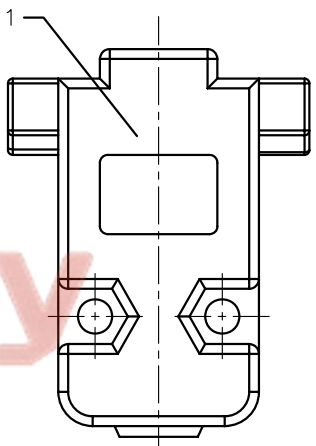
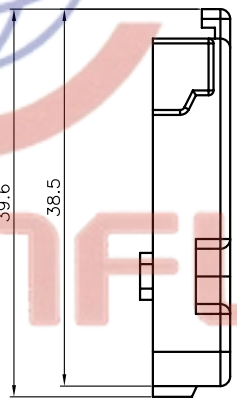
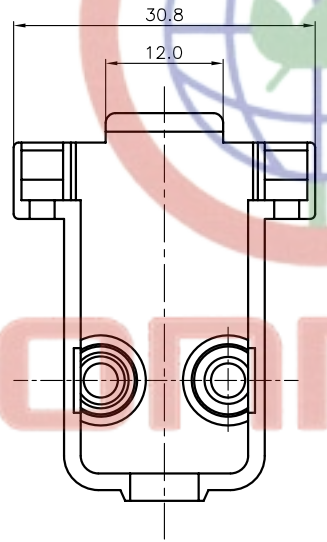
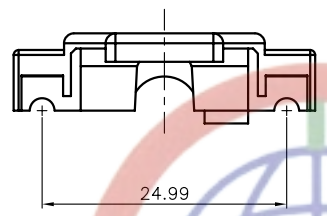
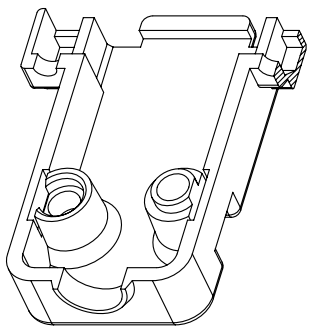

Tel: 86-574-63508707  
Fax: 86-574-63510817

GENERAL TOLERANCE		ANGLE TOLERANCE		PROJECTION	TITLE
X. ±0.60	.X ±0.38	.X ±5°	.X ±3°	mm	D-SUB 9pin Cover Chromium Plated
.XX ±0.25		.XX ±2°			SERIES DS1046 SERIES
DRAWING TYPE	CUSTOMER	Add: West Lake No. 11, Hangzhou, China			
SCALE	1:1	SHEET	1 OF 1		
DRAWING NO.	C-DS1046-09XXX				

**晨翔电子有限公司**  
**CONNFLY CONNFLY ELECTRONIC CO. LTD**

REV.	DESCRIPTION	DRAWN	CHECKED	APPROVED
A	NEW RELEASE	LJH 05/18/05'		

NOTES:

1. PART NUMBER CODE:  
DS1046 - 15 X X X

Bolt type  
L: Long  
S: Short

Packing type  
1: Mix packing  
2: Separation packing

Cover Material  
C: Chromium Plated

Positions  
15: 15pin

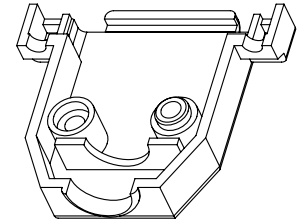

BOM LIST			
ITEM	PART NAME	Q'ty	NOTES
1	PLASTIC HOOD	2	ABS
2	BOLT	2	#4-40
3	NUT	2	M3
4	LONG SCREW	2	M3
5	SMALL WASHER	2	
6	SHORT SCREW	2	M3
7	MIDDLE WASHER	2	M3

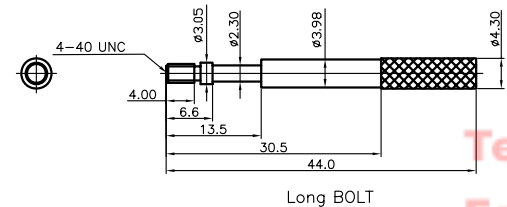
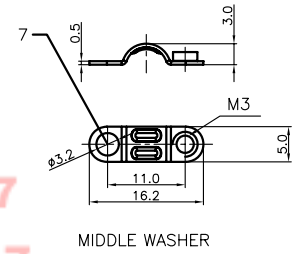
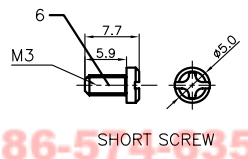
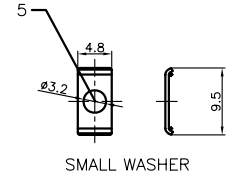
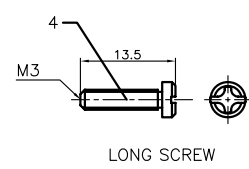
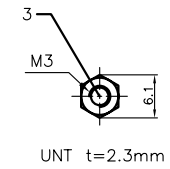
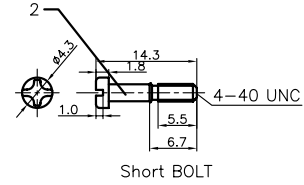
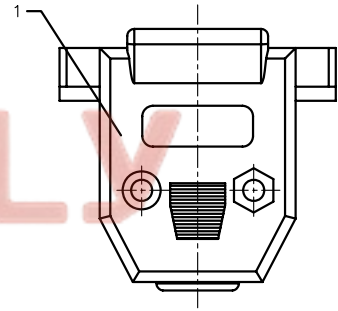
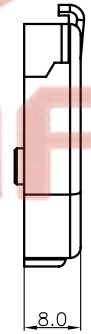
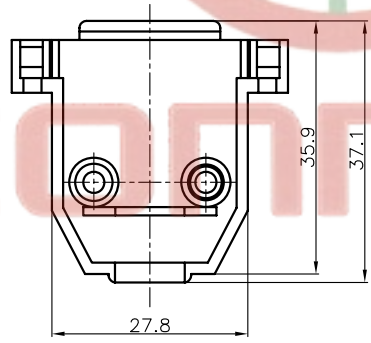
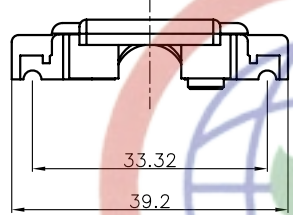

Tel: 86-574-63508787  
Fax: 86-574-63510817

GENERAL TOLERANCE		ANGLE TOLERANCE		PROJECTION	TITLE
X.	±0.60	X.	±5°	mm	D-SUB 15pin Cover Chromium Plated
.X	±0.38	.X	±3°		
.XX	±0.25	.XX	±2°		
DRAWING TYPE		COSTOMER		SHEET SIZE	SERIES
SCALE		1:1		A4	DS1046 SERIES
DRAWING NO.		C-DS1046-15XXX		SHEET NO.	
				1 OF 1	

晨翔电子有限公司  
CONNFY CONNFY ELECTRONIC CO. LTD

REV.	DESCRIPTION	DRAWN	CHECKED	APPROVED
A	NEW RELEASE	LJH 10/26/05'		

BOM LIST			
ITEM	PART NAME	Q'ty	NOTES
1	PLASTIC HOOD	2	ABS
2	BOLT	2	#4-40
3	NUT	2	M3
4	LONG SCREW	2	M3
5	SMALL WASHER	2	
6	SHORT SCREW	2	M3
7	BIG WASHER	2	M3

NOTES:  
 1. PART NUMBER CODE:  
 DS1046 - 25 X X X

- Bolt type  
 L: Long  
 S: Short
- Packing type  
 1: Mix packing  
 2: Separation packing
- Cover Material  
 C: Chromium Plated
- Positions  
 25: 25pin

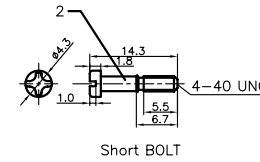
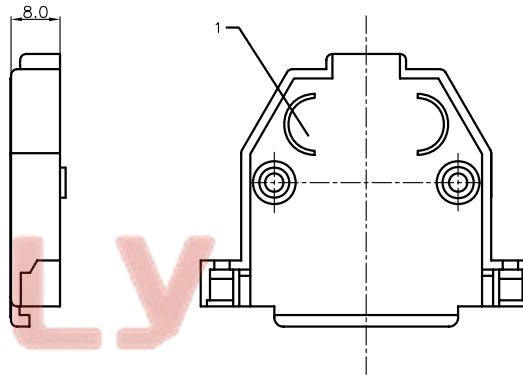
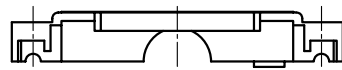
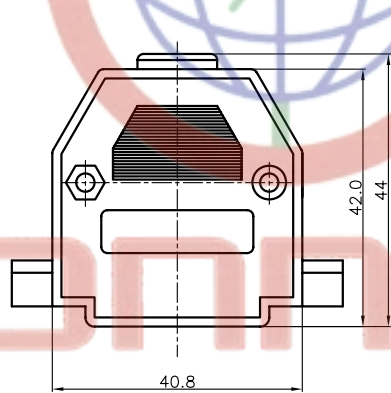
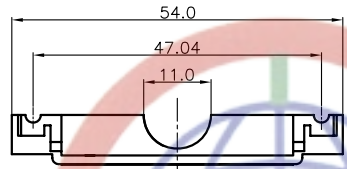

Short BOLT

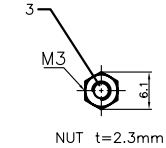

NUT t=2.3mm

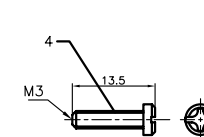

LONG SCREW

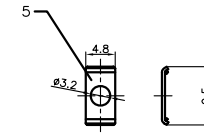

SMALL WASHER

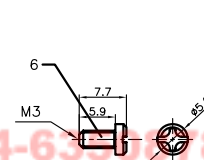

SHORT SCREW

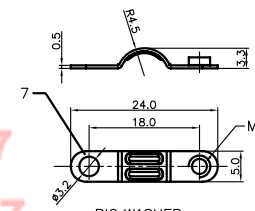

BIG WASHER

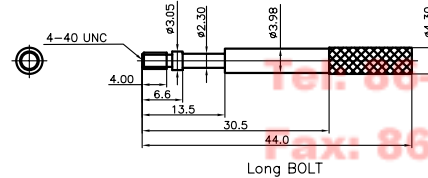

Long BOLT

GENERAL TOLERANCE		ANGLE TOLERANCE		PROJECTION	TITLE
X.	±0.60	X.	±5°	mm	D-SUB 25pin Cover Chromium plated
.X	±0.38	.X	±3°	A4	SERIES DS1046 SERIES
.XX	±0.25	.XX	±2°		
DRAWING TYPE	CUSTOMER		Add: West Gate No. 11, West Gate, Shenzhen, China		
SCALE	1:1	SHEET	1 OF 1		
DRAWING NO.	C-DS1046-25XXX				

**晨翔电子有限公司**  
**CONNFLY CONNFLY ELECTRONIC CO. LTD**

REV.	DESCRIPTION	DRAWN	CHECKED	APPROVED
A	NEW RELEASE	LJH 10/26/05'		

BOM LIST			
ITEM	PART NAME	Q'ty	NOTES
1	PLASTIC HOOD	2	ABS
2	BOLT	2	#4-40
3	NUT	2	M3
4	LONG SCREW	2	M3
5	SMALL WASHER	2	
6	SHORT SCREW	2	M3
7	BIG WASHER	2	M3

NOTES:  
1. PART NUMBER CODE:  
DS1046 - 37 X X X

Bolt type  
L: Long  
S: Short

Packing type  
1: Mix packing  
2: Separation packing

Cover Material  
C: Chromium Plated

Positions  
37: 37pin

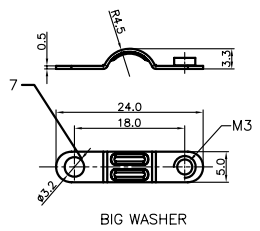
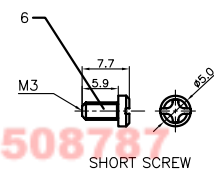
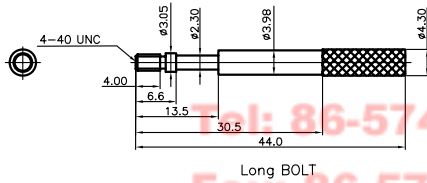
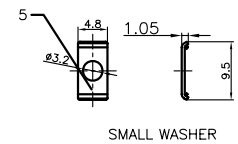
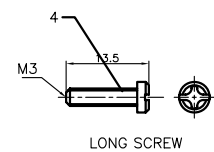
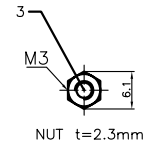
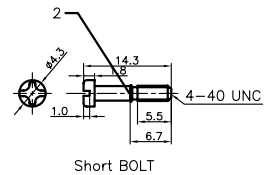
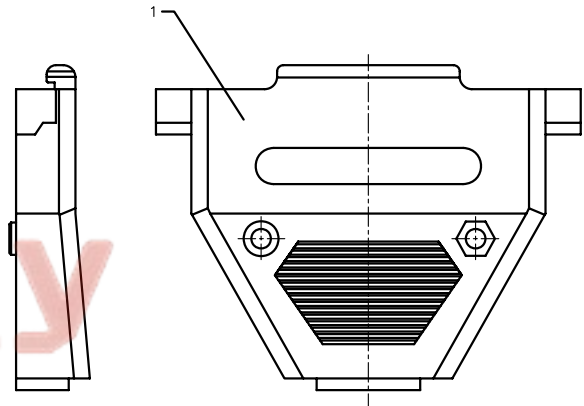
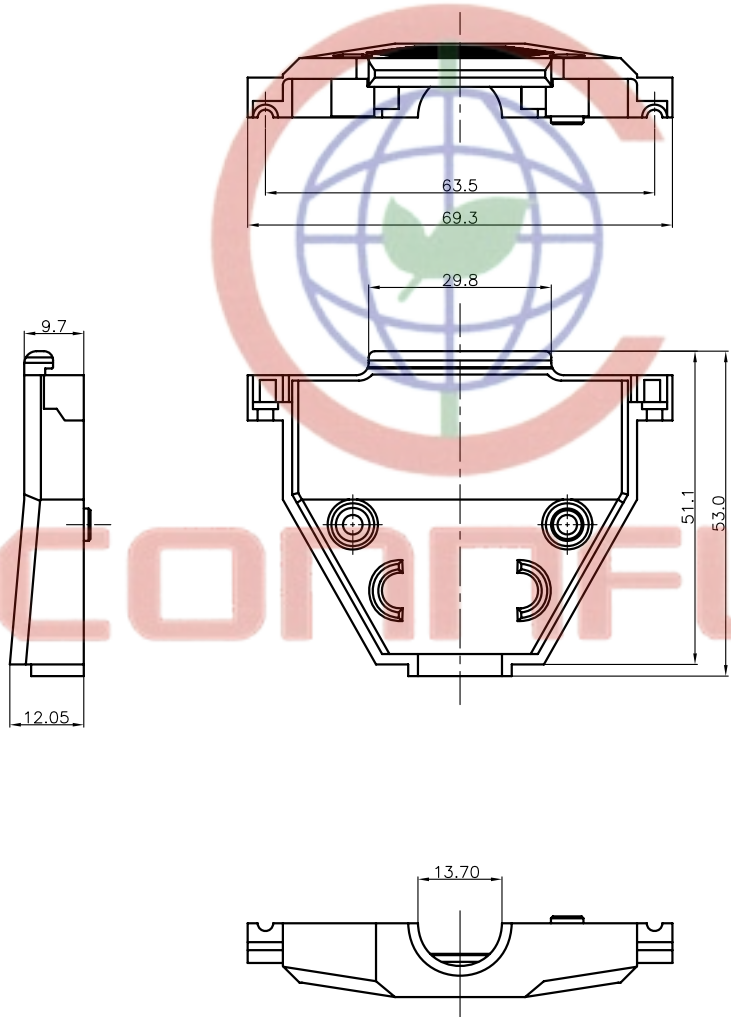
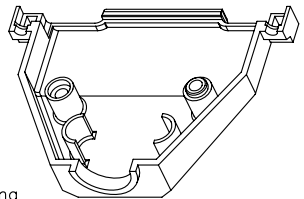

Tel: 86-574-63508787  
Fax: 86-574-63510817

GENERAL TOLERANCE		ANGLE TOLERANCE		PROJECTION	TITLE
X.	±0.60	X.	±5°	mm	D-SUB 37pin Cover Chromium plated
.X	±0.38	.X	±3°	UNITS	
.XX	±0.25	.XX	±2°	SHEET SIZE	A4 SERIES DS1046 SERIES
DRAWING TYPE	COSTOMER		DRAWING NO. C-DS1046-37XXX		
SCALE	1:1	SHEET	1 OF 1		

晨翔电子有限公司  
CONNFLY CONNFLY ELECTRONIC CO. LTD